

PLAN VIEW AT TOP STAIR
SCALE: 1/2"=1'-0"

STAIR DIAMETER	DIMENSION							
	1"0"	1"2"	1"4"	1"6"	1"8"	2"0"	2"2"	2"4"
40"	20"	24"	44"	22"	22"	44"		
48"	24"	28"	52"	26"	26"	52"		
52"	26"	30"	56"	28"	28"	56"		
60"	31"	35"	66"	33"	33"	66"		
64"	33"	37"	70"	35"	35"	70"		
72"	37"	41"	78"	39"	39"	78"		
78"	41"	45"	86"	43"	43"	86"		

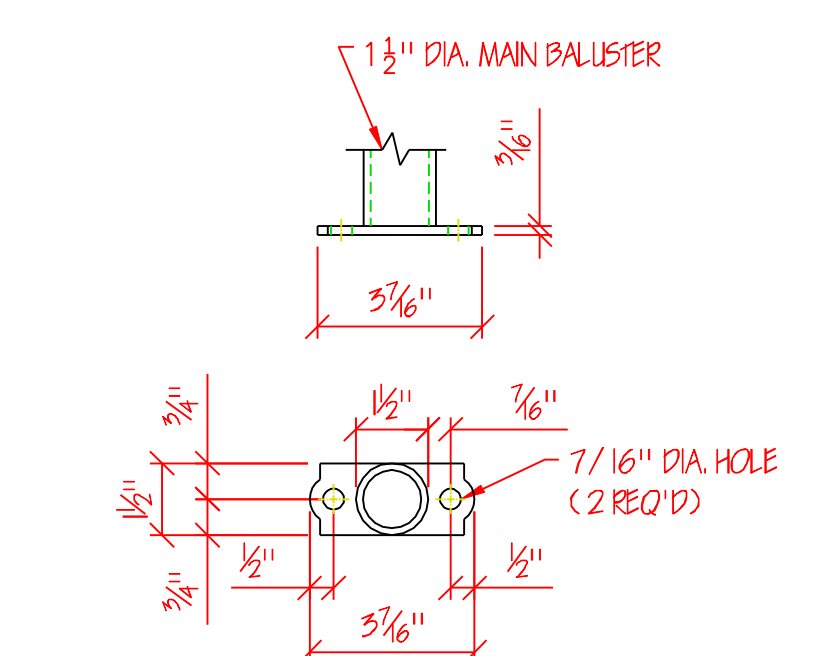

DETAIL III
SCALE: 3/4"=1'-0"

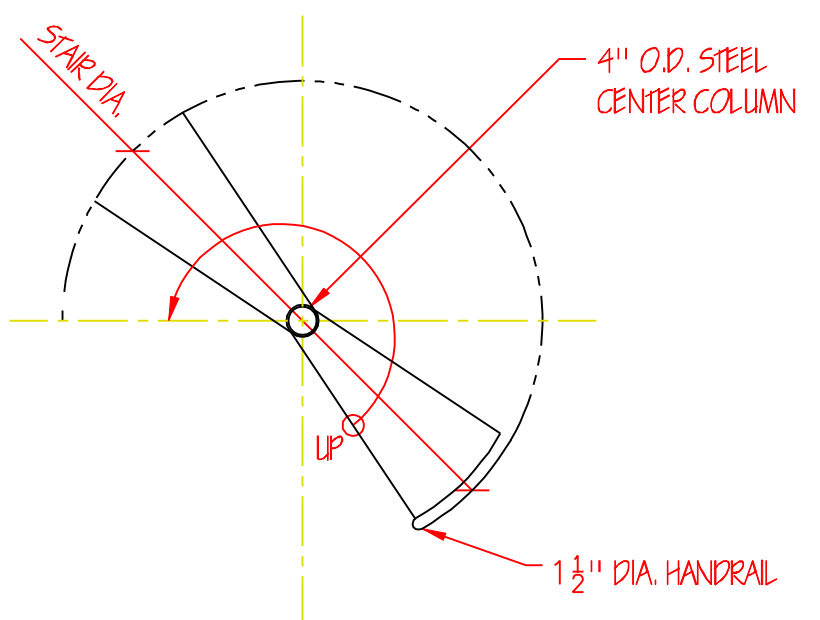

PLAN VIEW AT BOTTOM
SCALE: 1/2"=1'-0"

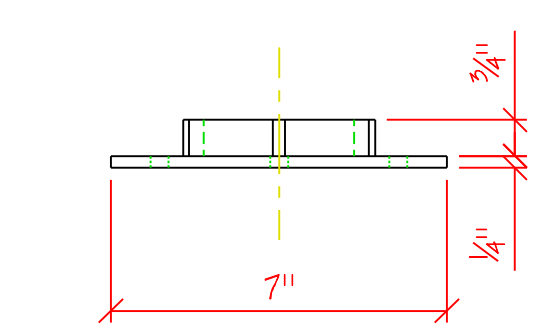
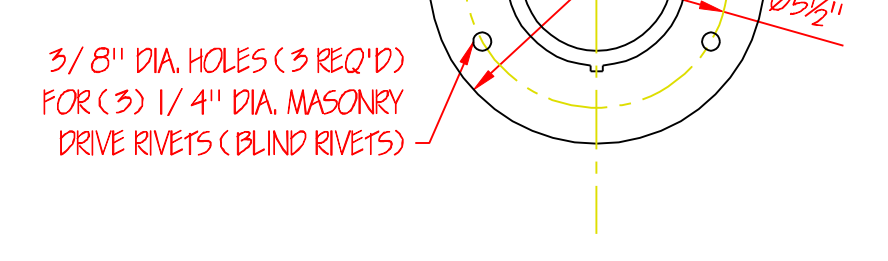

BASE PLATE DETAIL
SCALE: 3/4"=1'-0"

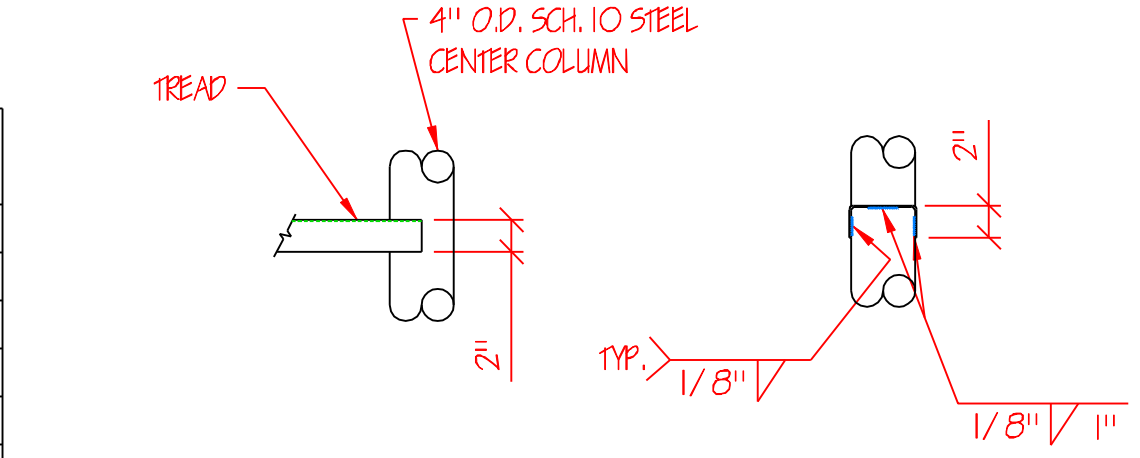

TREAD WELD DETAIL
SCALE: 1"=1'-0"

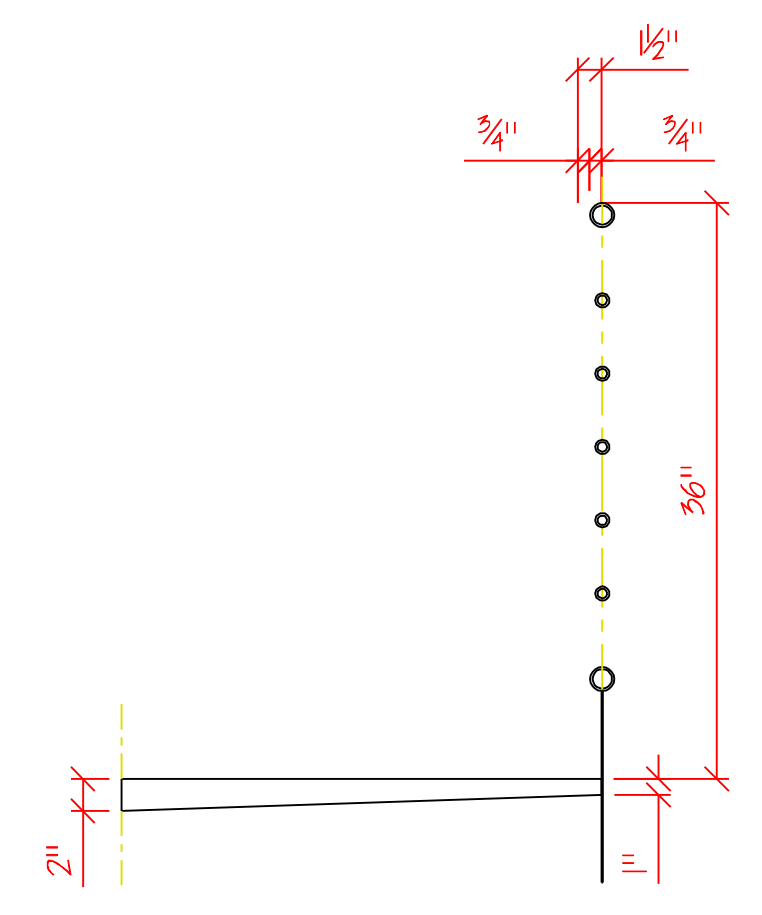

BALUSTER DETAIL
SCALE: 3/4"=1'-0"

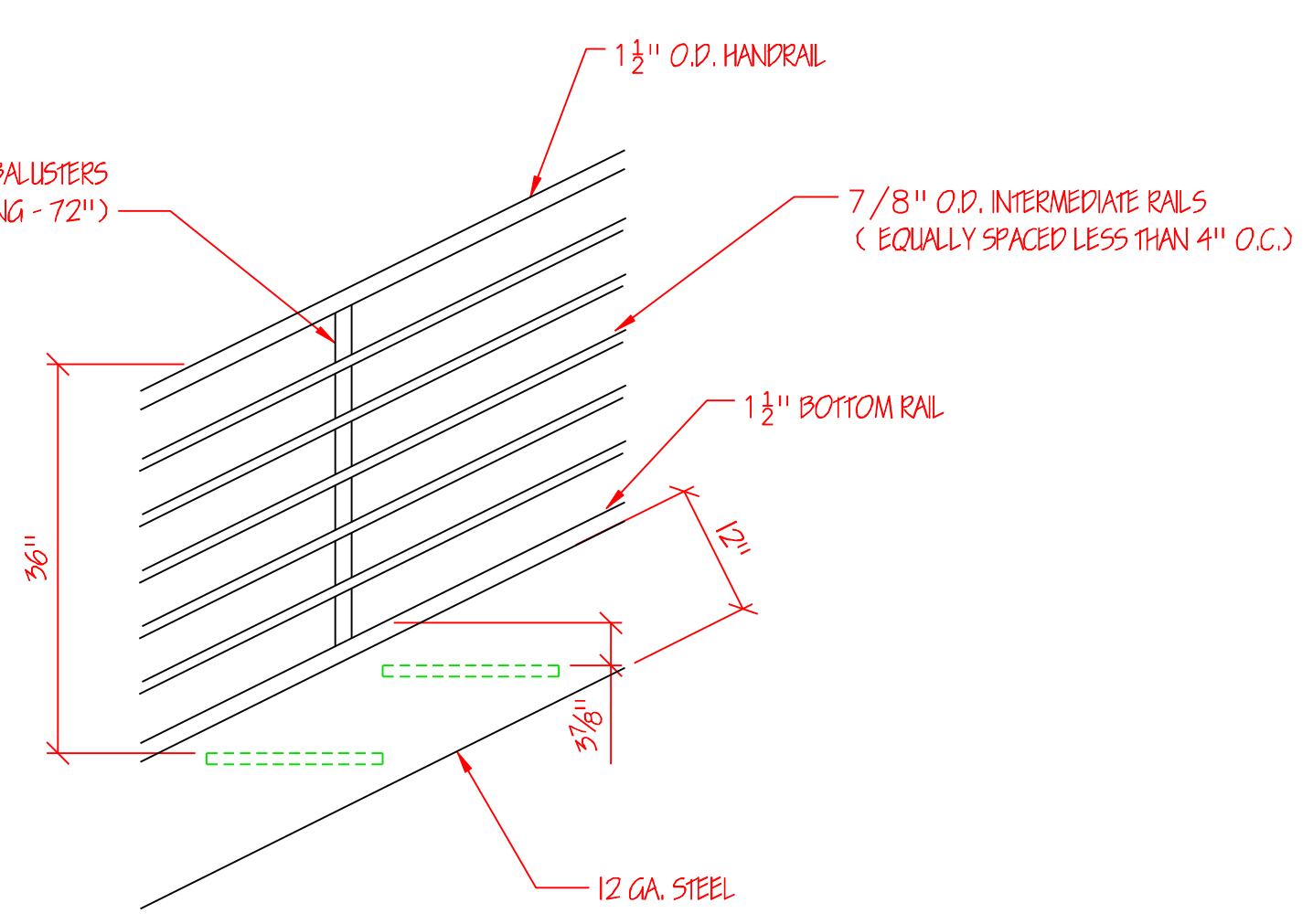

BALUSTER DETAIL
SCALE: 3/4"=1'-0"

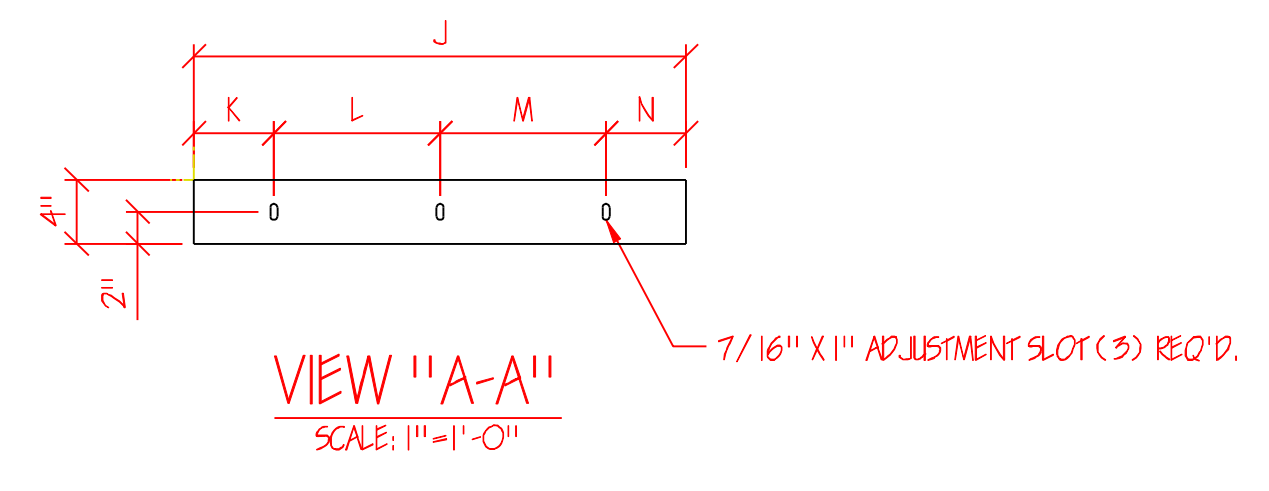

VIEW "A-A"
SCALE: 1"=1'-0"

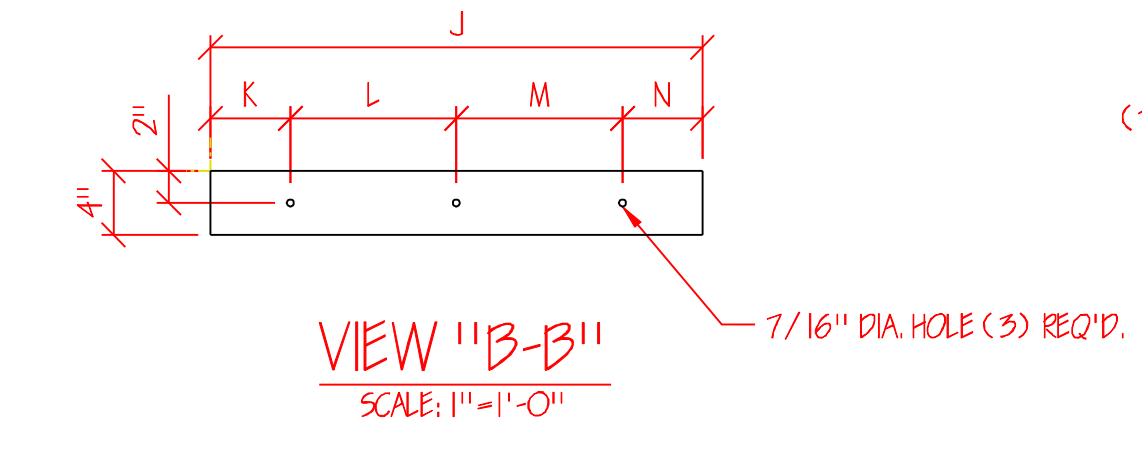

VIEW "B-B"
SCALE: 1"=1'-0"

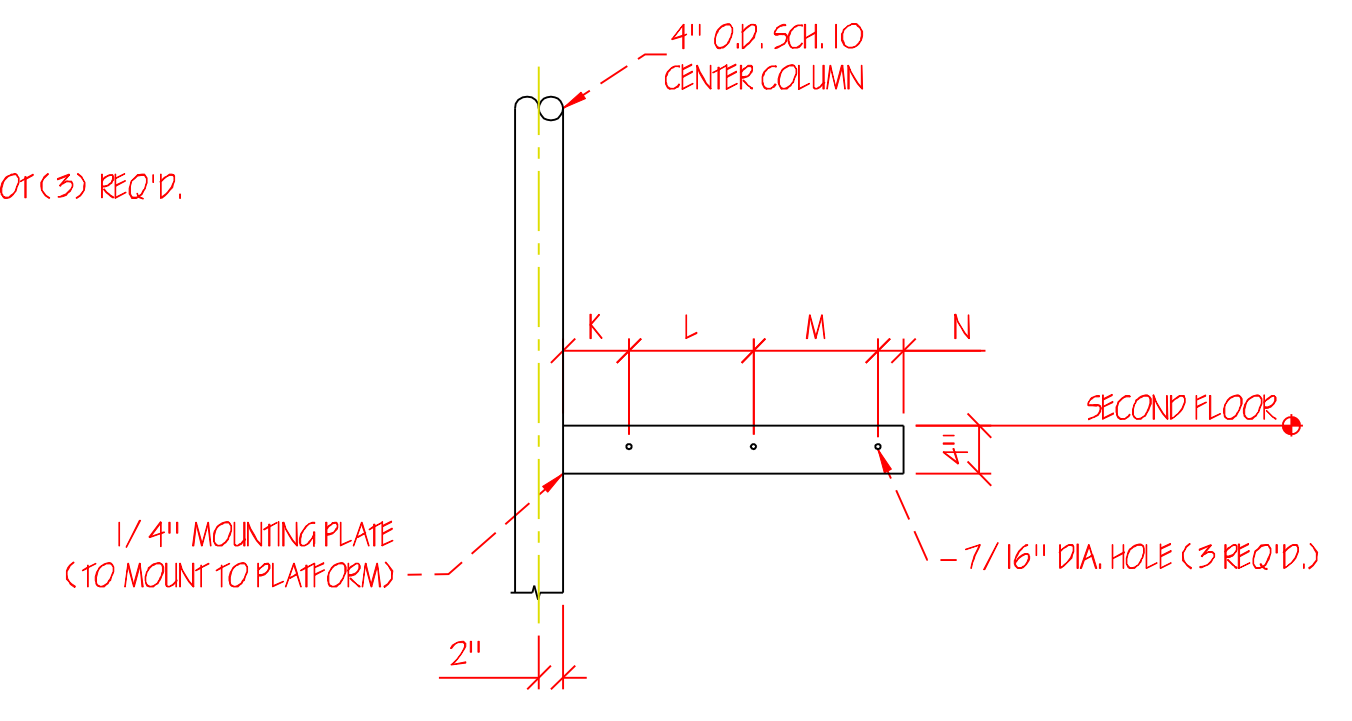

MOUNTING PLATE DETAIL
SCALE: 3/4"=1'-0"

STAIR DIAMETER	DIMENSION							
	1"0"	1"2"	1"4"	1"6"	1"8"	2"0"	2"2"	2"4"
40"	19.75"	9.00"	4.88"	4.88"	9.00"	---	---	---
48"	25.75"	9.00"	6.88"	6.88"	9.00"	---	---	---
52"	29.75"	9.00"	7.88"	7.88"	9.00"	---	---	---
60"	30.75"	9.00"	10.58"	10.58"	9.00"	---	---	---
64"	32.75"	4.00"	12.58"	12.58"	4.00"	---	---	---
72"	36.75"	9.00"	8.88"	9.00"	8.88"	9.00"	---	---

PLATFORM & MOUNTING PLATE SCHEDULE

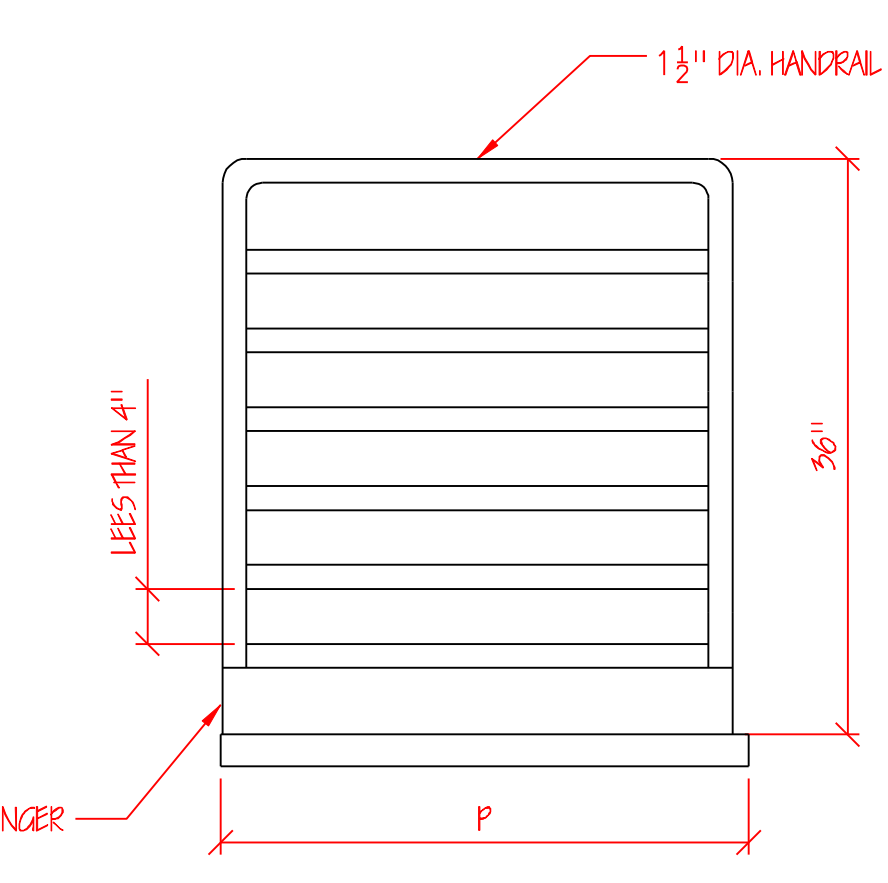

PLATFORM DETAIL
SCALE: 1"=1'-0"

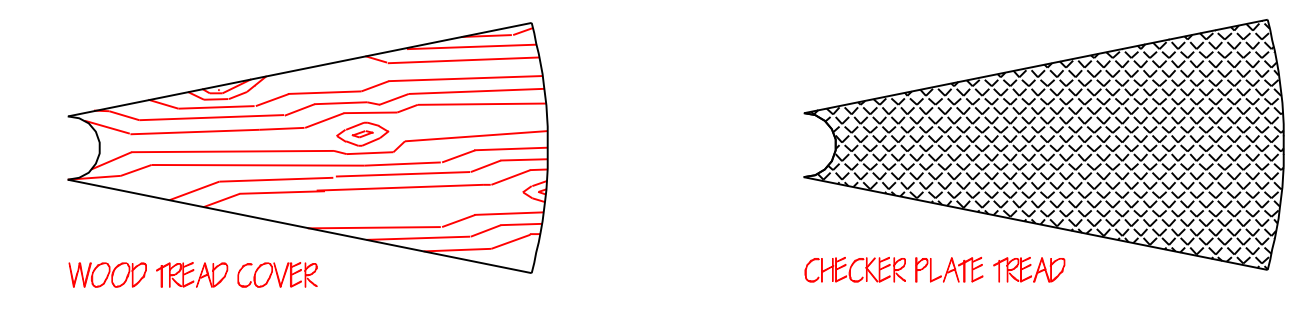

OPTIONAL TREAD STYLES
SCALE: 1"=1'-0"

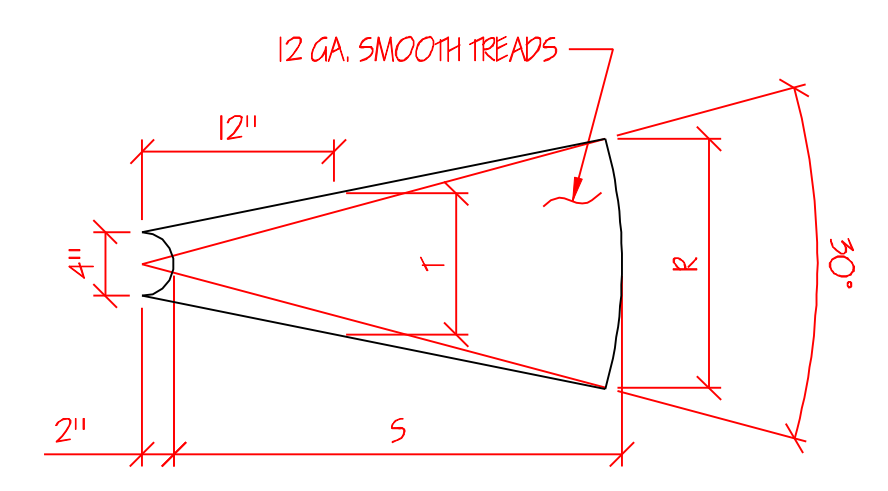

RADIUS TREAD DETAIL
SCALE: 1"=1'-0"

STAIR DIAMETER	DIMENSION		
	1"0"	1"2"	1"4"
40"	10 9/16"	18"	8 5/8"
48"	12 3/4"	22"	9 1/16"
52"	15 15/16"	24"	9 1/4"
60"	15 15/16"	28"	9 9/16"
64"	17"	30"	9 1/16"
72"	19 1/8"	34"	9 7/8"
78"	20 3/4"	37"	10"

TREAD SCHEDULE

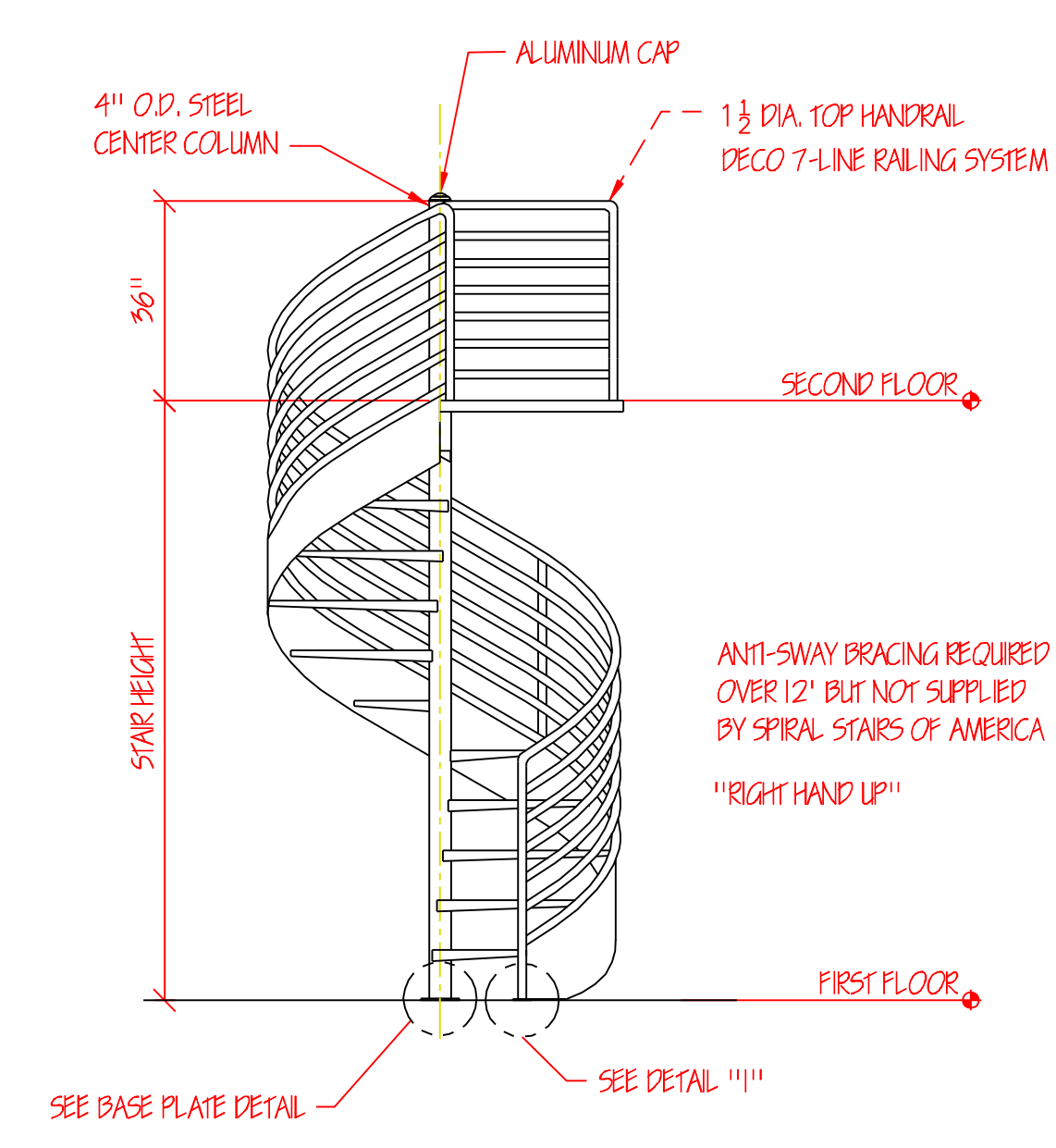

SIDE ELEVATION
SCALE: 3/8"=1'-0"

STAIR HEIGHT SCHEDULE - 30° TREADS 8 1/2" MIN. - 9 1/2" MAX. RISERS			
STAIR HEIGHT	NUMBER OF TREADS	NUMBER OF RISERS	DEGREES OF ROTATION
76 1/2" - 89 1/2"	8	9	240°
10 - 95"	9	10	270°
10 - 104 1/2"	10	11	300°
10 - 114"	11	12	360°
10 - 129 1/2"	12	13	360°
10 - 155"	15	14	390°
10 - 142 1/2"	14	15	420°
10 - 152"	15	16	450°
10 - 161 1/2"	16	17	480°
10 - 171"	17	18	510°

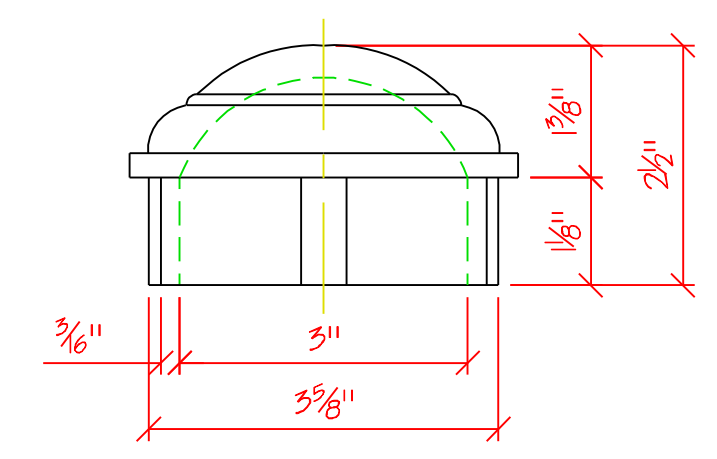

ALUMINUM CAP DETAIL
SCALE: 6"=1'-0"

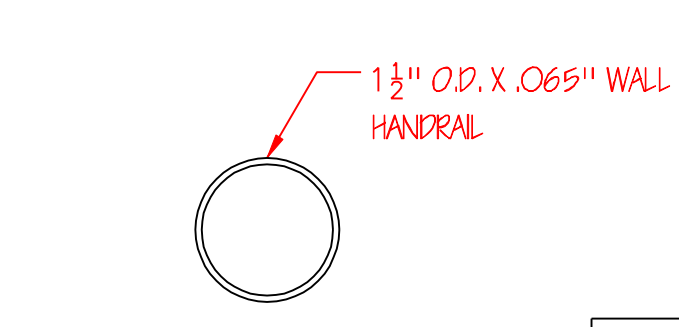

HANDRAIL PROFILE
SCALE: 6"=1'-0"

APPROVED AS IS FOR CONSTRUCTION
 APPROVED AS NOTED FOR CONSTRUCTION
 REJECTED, PLEASE RESUBMIT
 SIGNED: _____
 DATE: _____

TITLE: SPIRAL STAIR W/ DECO 7 LINE RAILING SYSTEMS & COVER STRINGER
 CUSTOMER: STEEL DECO SPIRAL STAIR
 DRAWN BY: MIBERLLA
 DATE: 09/05/2009
 SCALE: NOTED
 DWA NO.: SAWDSCS
 SPIRAL STAIRS OF AMERICA
 1700 SPIRAL COURT
 EBRE, PENNSYLVANIA 16910
 (814) 898-9700 FAX: (814) 899-9159